



Pinto Horse Association of Ohio

Pattern Book

“Summer Warm Up”

May 20-21, 2017

Fulton County Fairgrounds

2017 PINTO HORSE ASSOCIATION OF OHIO SHOWBILL

SATURDAY 8:30 AM		BREAK - DRIVING WARM UP	
J-1	All Breed-Jackpot Halter	52	Pony Pleasure Driving
1	Stock Type Halter-Mares, All Ages	53	Horse Pleasure Driving
2	Grand & Reserve Stock Type Halter Mares	54	AM Pleasure Driving, Horse
3	Stock Type Halter-Geldings/Stallions, All Ages	55	Miniature Horse Pleasure Driving
4	Grand & Reserve Stock Type Halter Geldings/Stallions	56	Disciplined Rail Driving Miniature Horse
5	Miniature Horse Halter, A & B Divisions, Mares	57	Ideal Pinto Pleasure Driving, Miniature Horse BREAK
6	Grand & Reserve Miniature Halter-Mares	58	Hunter Under Saddle
7	Miniature Horse Halter, A & B Divisions, Geldings & Stallions	59	AM Hunter Under Saddle
8	Grand & Reserve Miniature Horse Halter-Geldings & Stallions	60	YA Hunter Under Saddle
9	Pony Halter All Types, All Sexes	J-3	All Breed-Jackpot Walk/Trot English Pleasure
10	Grand & Reserve Pony Halter	61	YA Walk/Trot English Pleasure 11 & Under
11	Grand & Reserve Pony Halter	62	AM Walk/Trot English Pleasure
12	Solid Registry Halter, All Ages/Sexes/Types	J-4	All Breed-Jackpot English Pleasure
J-2	Grand & Reserve Solid Registry Halter	63	English Pleasure Stock Types
13	All Breed-Jackpot Showmanship	64	English Pleasure Hunter Types
14	AM Western Showmanship Pony/Mini	65	English Pleasure-Pleasure Saddle Types
15	YA Western Showmanship Pony/Mini	66	Solid Registry English Pleasure
16	AM Novice Showmanship, Western/English	67	AM Novice English Pleasure All Types/Seats
17	JR AM Western Showmanship	68	JR AM English Pleasure
18	SR AM Western Showmanship	69	SR AM English Pleasure
19	Elite AM Western Showmanship	70	Elite AM English Pleasure
20	YA Western Showmanship 14 - 18	71	YA English Pleasure 13 & Under
21	YA Walk/Trot Showmanship West/Eng 11 & Under	72	YA English Pleasure 14 - 18
22	Tobiano Color Horse All Types	73	English Pleasure Jr Horse
23	Overo Color Horse All Types	74	English Pleasure Sr Horse
24	AM Tobiano Color Horse All Types	J-5	All Breed-Jackpot Walk/Trot English Equitation
25	AM Overo Color Horse All Types	75	YA Walk/Trot English Equitation 11 & Under
26	YA Tobiano Color Horse All Types	76	AM Walk/Trot English Equitation
27	YA Overo Color Horse All Types	J-6	All Breed-Jackpot English Equitation
28	AM Pony/Miniature Horse Halter, All Sexes	77	AM Novice Equitation
29	YA Pony/Miniature Halter, Mares & Geldings	78	JR AM Equitation
30	Miniature Horse Color	79	SR AM Equitation
31	Pony Color	80	Elite AM Equitation
32	Hunter Type Halter-Mares, All Ages	81	YA Equitation 13 & Under
33	Grand & Reserve Hunter Type Halter-Mares	82	YA Equitation 14 - 18
34	Hunter Type Halter-Geldings/Stallions, All Ages	83	Disciplined Rail English
35	Grand & Reserve Hunter Type Halter-Geldings/Stallions	84	AM Disciplined Rail English
36	Pleasure Saddle Type Halter-Mares, All Ages	85	YA Disciplined Rail English
37	Grand & Reserve Pleasure Type Halter-Mares	86	Ideal Pinto English All Types
38	Pleasure Saddle Type Halter-Geldings/Stallions, All Ages	87	YA Ideal Pinto English
39	Grand & Reserve Pleasure Type Halter-Geldings/Stallions	88	AM Ideal Pinto English
40	AM Horse Halter-Mares, All Ages	SUNDAY 8:30 AM	
41	AM Horse Halter-Geldings/Stallions, All Ages	89	Miniature Hunter in Hand
42	YA Horse Halter-Mares, All Types	90	Pony Jumping in Hand
43	YA Horse Halter-Geldings, All Types	91	Miniature Jumping in Hand
44	Yearling Longe Line	92	AM Pony/Miniature Jumping in Hand
45	AM English Showmanship Pony/Mini	93	YA Pony/Miniature Jumping in Hand
46	YA English Showmanship Pony/Mini	94	Pony Trail in Hand
47	JR AM English Showmanship	95	Miniature Trail in Hand
48	SR AM English Showmanship	96	AM Pony/Miniature Trail in Hand
49	Elite AM English Showmanship	97	YA Pony/Miniature Trail in Hand
50	YA English Showmanship 13 & Under		
51	YA English Showmanship 14 - 18		
J-7	All Breed-Jackpot Trail	98	Trail Horse
98	Trail Horse	99	Solid Registry Trail
99	Solid Registry Trail	100	AM Novice Trail
100	AM Novice Trail	101	AM Trail
101	AM Trail	102	YA Trail
102	YA Trail	103	YA Walk/Trot Trail 11 & Under
103	YA Walk/Trot Trail 11 & Under	104	AM Walk/Trot Trail
104	AM Walk/Trot Trail	105	Western Dressage
105	Western Dressage	BREAK	
106	AM Pleasure Driving Pony/Miniature Horse	106	AM Pleasure Driving Pony/Miniature Horse
107	YA Pleasure Driving Pony/Miniature Horse	107	YA Pleasure Driving Pony/Miniature Horse
108	AM Reinsmanship Pony/Miniature Horse	108	AM Reinsmanship Pony/Miniature Horse
109	AM Reinsmanship Pony/Miniature Horse	109	AM Reinsmanship Pony/Miniature Horse
110	AM Disciplined Rail Driving Pony/Miniature Horse	110	AM Disciplined Rail Driving Pony/Miniature Horse
111	YA Disciplined Rail Driving Pony/Miniature Horse	111	YA Disciplined Rail Driving Pony/Miniature Horse
112	AM Ideal Pinto Driving Pony/Miniature Horse	112	AM Ideal Pinto Driving Pony/Miniature Horse
113	YA Ideal Pinto Driving Pony/Miniature Horse	113	YA Ideal Pinto Driving Pony/Miniature Horse
J-8	All Breed-Jackpot Walk/Trot Western Pleasure	BREAK	
114	YA Walk/Trot Western Pleasure 11 & Under	J-8	All Breed-Jackpot Walk/Trot Western Pleasure
115	AM Walk/Trot Western Pleasure	114	YA Walk/Trot Western Pleasure 11 & Under
J-9	All Breed-Jackpot Western Pleasure	115	AM Walk/Trot Western Pleasure
116	Western Pleasure Stock Types	J-9	All Breed-Jackpot Western Pleasure
117	Western Pleasure Hunter Types	116	Western Pleasure Stock Types
118	Western Pleasure-Pleasure Saddle Types	117	Western Pleasure Hunter Types
119	Solid Registry Western Pleasure	118	Western Pleasure-Pleasure Saddle Types
120	AM Novice Western Pleasure All Types	119	Solid Registry Western Pleasure
121	JR AM Western Pleasure	120	AM Novice Western Pleasure All Types
122	SR AM Western Pleasure	121	JR AM Western Pleasure
123	Elite AM Western Pleasure	122	SR AM Western Pleasure
124	YA Western Pleasure 13 & Under	123	Elite AM Western Pleasure
125	YA Western Pleasure 14 - 18	124	YA Western Pleasure 13 & Under
126	Western Pleasure Junior Horse	125	YA Western Pleasure 14 - 18
127	Western Pleasure Senior Horse	126	Western Pleasure Junior Horse
128	YA Lead-Line 8 & Under	127	Western Pleasure Senior Horse
J-10	All Breed-Jackpot Walk/Trot Horsemanship	BREAK	
129	YA Walk/Trot Horsemanship 11 & Under	128	YA Lead-Line 8 & Under
130	AM Walk/Trot Horsemanship	J-10	All Breed-Jackpot Walk/Trot Horsemanship
J-11	All Breed-Jackpot Horsemanship	129	YA Walk/Trot Horsemanship 11 & Under
131	AM Novice Horsemanship	130	AM Walk/Trot Horsemanship
132	JR AM Horsemanship	J-11	All Breed-Jackpot Horsemanship
133	SR AM Horsemanship	131	AM Novice Horsemanship
134	Elite AM Horsemanship	132	JR AM Horsemanship
135	YA Horsemanship 13 & Under	133	SR AM Horsemanship
136	YA Horsemanship 14 - 18	134	Elite AM Horsemanship
137	Disciplined Rail Western	135	YA Horsemanship 13 & Under
138	AM Disciplined Rail Western	136	YA Horsemanship 14 - 18
139	YA Disciplined Rail Western	137	Disciplined Rail Western
140	Ideal Pinto Western All Types	138	AM Disciplined Rail Western
141	AM Ideal Pinto Western	139	YA Disciplined Rail Western
142	AM Ideal Pinto Western	140	Ideal Pinto Western All Types
143	YA Bareback Western Horsemanship	141	AM Ideal Pinto Western
144	AM Bareback Western Horsemanship	142	AM Ideal Pinto Western
		143	YA Bareback Western Horsemanship
		144	AM Bareback Western Horsemanship

Walk/Trot Exhibitors may not cross enter into canter classes except if only entered in Jackpot W/T
PLEASE USE THE SAME BACK NUMBER FOR THE ENTIRE PHAIO SHOW SEASON

2017 PINTO HORSE ASSOCIATION OF OHIO SHOWS

Dates	Locations	Show Manager	Show Manager	Judges	Please Read Entire Sheet Carefully!! FORMS NEEDED When Pre-Entering:
April 15 & 16	"Spring Fling" Champions Center Springfield, OH	Dick & Nancy Bredemeier nbredem1@kent.edu 330-221-6562	Desiree Herchek desireeherchek@yahoo.com 330-309-1418	A. Mary Ann Fielitz, OH B. Sandra Guy-Fox, MI C. Melinda Guy, MI D. Stephen Shank, NY	Entry Forms For Weekend Fee Summary Sheet Copy of Registration Papers (Both Sides) Copy of Membership Cards Check made out to: PTHAO
May 20 & 21	"Summer Warm Up" Fulton Co. Fairgrounds Wauseon, OH	Betty Jo Hickman bjhickman90@gmail.com 440-213-9174	Megan Herner herner7@yahoo.com 419-681-0133	A. Mike Carlson, IN B. Larry Cline, IN C. Carol Craig, IN D. Chris Stine, OH	Please Send Pre-entries and Stalls To: Tarmy Braden 423 State Route 61 E Norwalk, OH 44857 419-706-9261
July 15 & 16	"Lots O' Spots" Findlay University Findlay, OH	Angie Wolfe wolfegal70@gmail.com 419-706-9512	Shelly Nalle-Icenhouer shelle@amfam.com 419-651-4127	A. Pauline Crull, IN B. Christie King-Moree, IN C. Duke Neff, MO D. James Simpson, CAN	
Sept. 23 & 24	"Fall Wind Up" Fulton Co. Fairgrounds Wauseon, OH	Amy Leibold leibold1043@yahoo.com 419-706-6135	Pete Thornton threeponys@frontier.com 330-527-7669	A. Tim Abler, MI B. Karen Maas, MI C. Daren Wright, OH D. Stephanie McConnell Hill, IN	PLEASE USE THE SAME BACK NUMBER FOR THE ENTIRE PTHAO SEASON

Entry Fees:	Jackpot Classes:	Stalls, Camping and Grounds Fees:
<p>\$125.00 Pre-Entry and \$150.00 Post Entry Unlimited Classes</p> <p>\$25.00 Per Class</p> <p>\$1.00 Per class for every class entered per PTHA</p> <p>\$5.00 PTHA ROM Fee Per Judge = \$20.00 Per Horse</p> <p>\$10.00 Office Fee Per Horse</p> <p>Walk/Trot and Leadline Entry Fee:</p> <p>\$5.00 Entry Fee per class for Leadline and Walk/Trot Classes (Unless horse is in weekend economy fee.) (PTHA Fees do not apply.)</p>	<p>Open to ANY Breed Horses - Do NOT have to be members of Ohio or PTHA to show a horse in Jackpot Classes</p> <p style="text-align: center;">To be Judged by 1 Judge</p> <p>Walk/Trot can cross enter into cantering classes</p> <p>\$10.00 Entry Fee Per Jackpot Class (Separate Entry Form)</p> <p>Payback for Jackpot Classes: PTHAO will retain 20% of Entry Fee 1st = 30%, 2nd = 20%, 3rd = 15%, 4th = 10% and 5th = 5%</p>	<p>Stalls =</p> <p>\$50.00 Springfield \$35.00 Wauseon \$60.00 Findlay</p> <p>Camping =</p> <p>\$60.00 Springfield \$45.00 Wauseon \$50.00 Findlay</p> <p>\$15.00/per Horse Grounds Fee for ANY Horse Unstalled Through Show Management</p> <p>Shavings will be available on the grounds</p>

PRE-ENTRIES should be mailed to the correct person and must be received one week prior to the show date. Pre-Entries may be canceled no later than the Thursday Preceding the show. Refunds will be given up to the show date with proof of injury to horse or exhibitor. No weather related refunds will be given. Checks for pre-entries will not be deposited until after the show. There will be a \$25.00 fee on all returned checks and subject to additional penalties.

ADDITIONAL INFORMATION: All of the above shows are approved for points by PTHA and PTHAO. Entries must be made in accordance with the current PTHA rules. All horse owners or lessees must show a current PTHA membership card or purchase one at the show. Owners, youth exhibitors, and amateur exhibitors must belong to PTHAO and submit their nomination forms and fees to the Point Secretary in order to be qualified for PTHAO year end awards. PTHA registration papers, type card, or photocopies of both sides of those items must be presented at the show office when entering the show. Show rules are those of the current PTHA National Rule Book. The show management reserves the right to cancel, combine, or split classes as entries warrant. By entering these shows, owners, lessees, and exhibitors agree that PTHA, PTHAO, the show grounds, and the show committee will not be held responsible for any losses, injuries, damages, or debts in connection with these shows. All dogs must be on a leash no longer than 6' while being lead and 10' when tied.

Horse/Pony/Miniature horses staying overnight must be in a stall
 PTHAO RULE: Amateur and Youth classes will be combined if less than 5 entries in any Amateur or Youth division. (Jr. & Sr. & Elite, 14-18 & 13 & under)

Western Showmanship

Classes J-2, 13, 14, 16, 17, 18, 19, 20

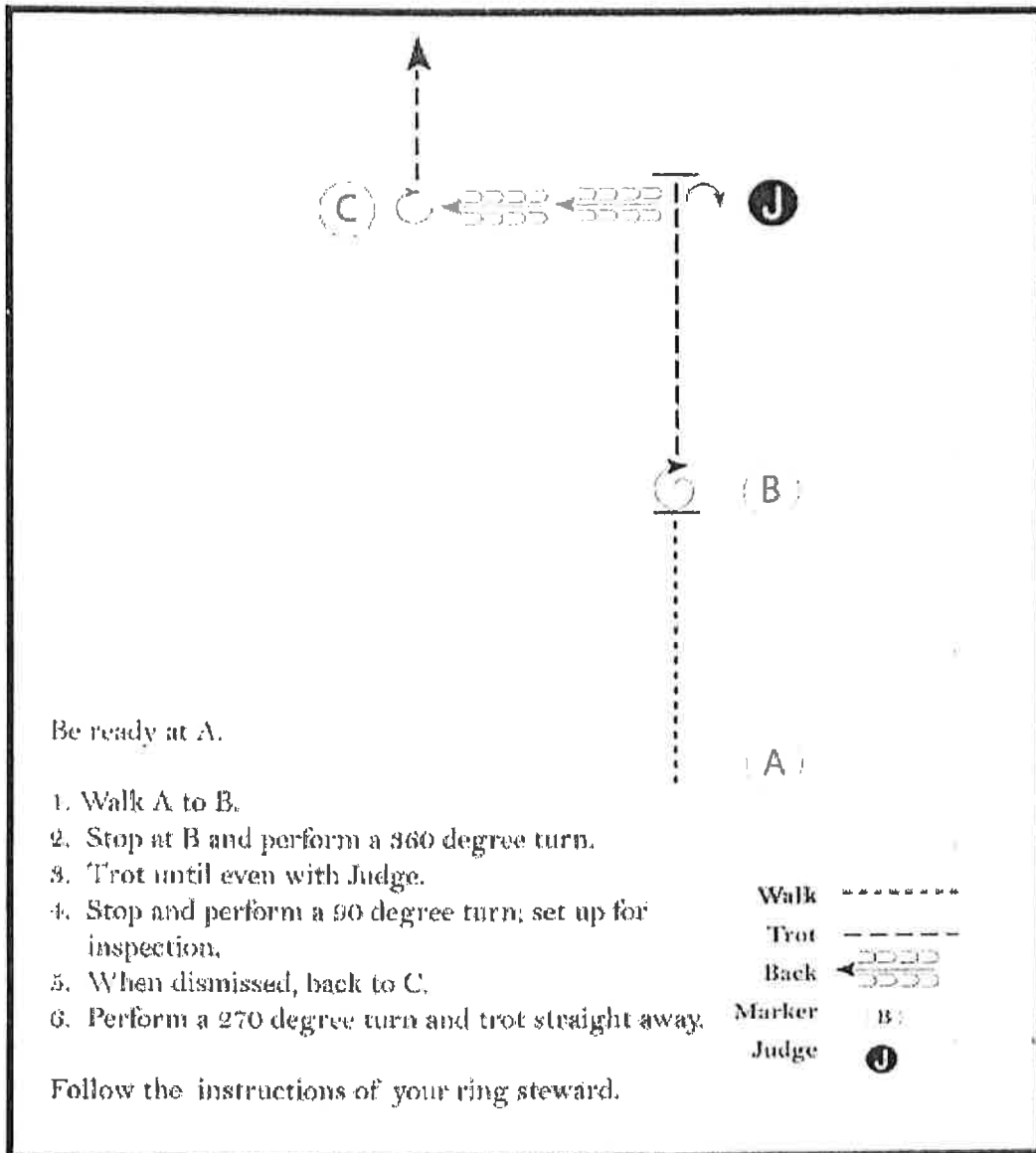

Showmanship

Novice Amateur and Walk/Trot

(English or Western)

Classes 15 and 21

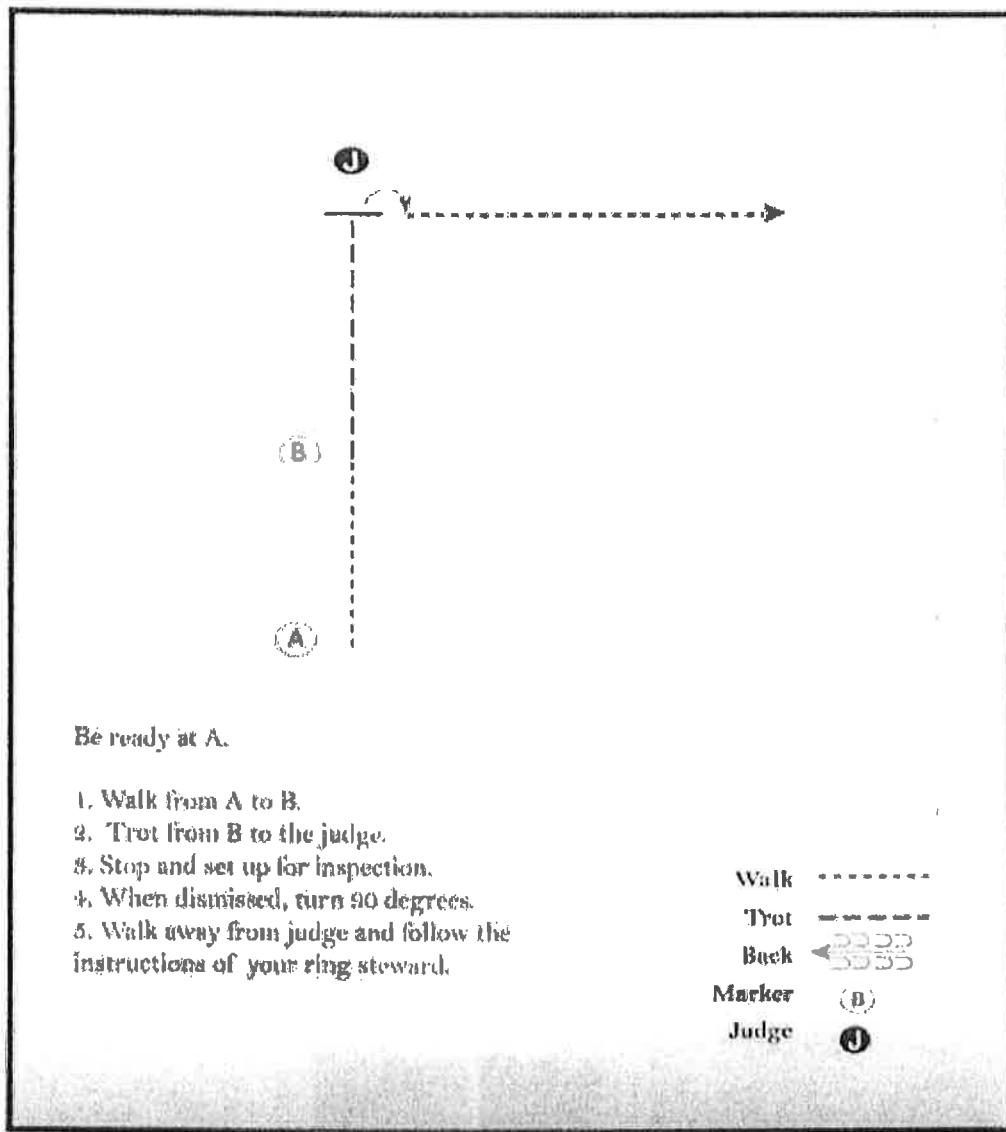

English Showmanship

Classes 45, 46, 47, 48, 49

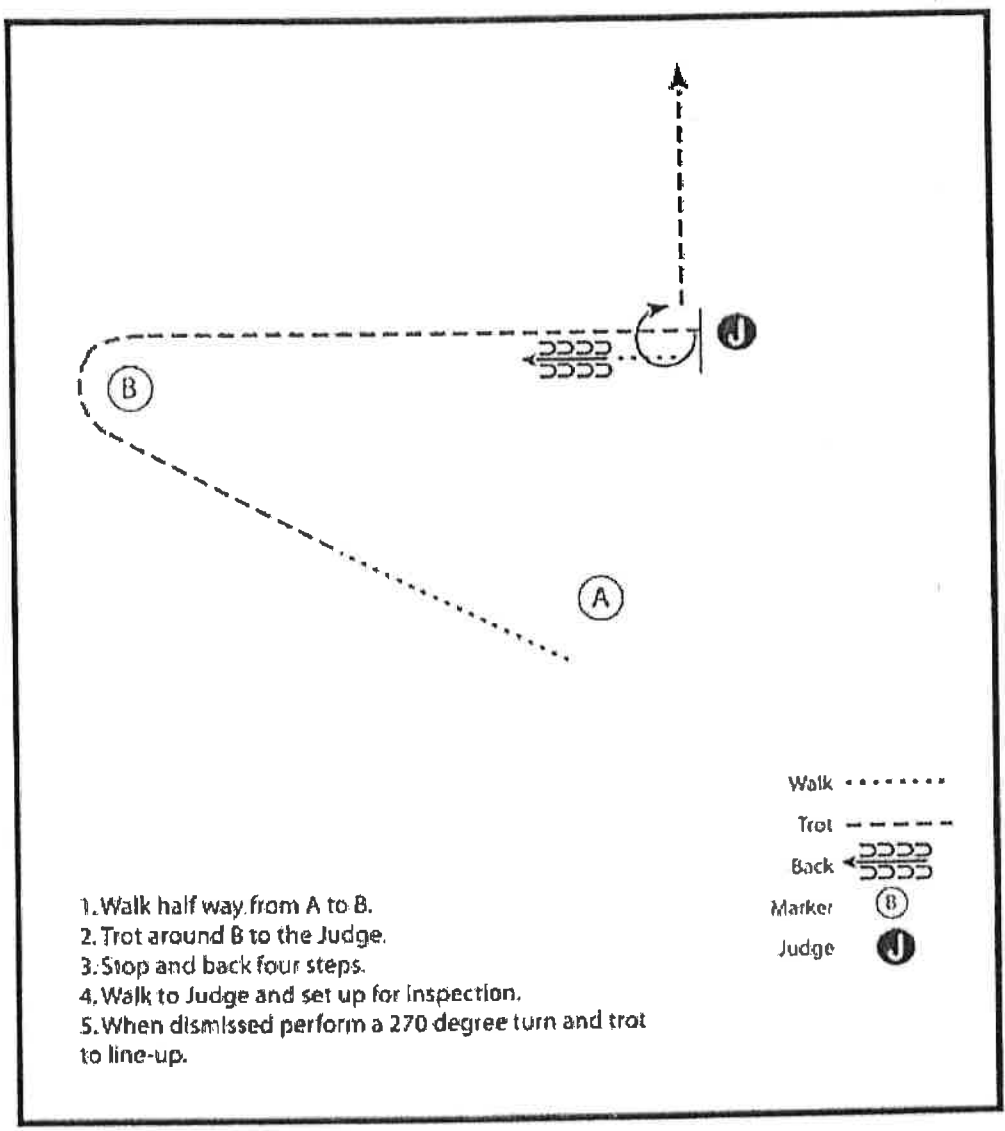

English Equitation – Walk/Trot

Classes J-5, 75, 76

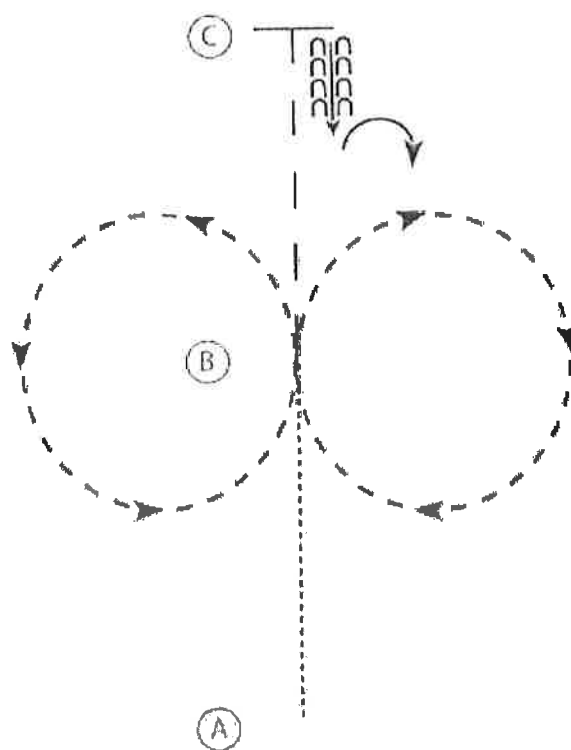

1. Walk A to B
2. Sitting trot circle to the right
3. Posting trot circle to the left
4. At B extend the trot to C
5. Stop at C and back 4 steps
6. Perform a 90 degree turn to the right

Walk
Trot - - - - -
Extended Trot - - - - -

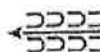
Back 

English Equitation

Classes J-6, 77, 78, 79, 80, 81, 82

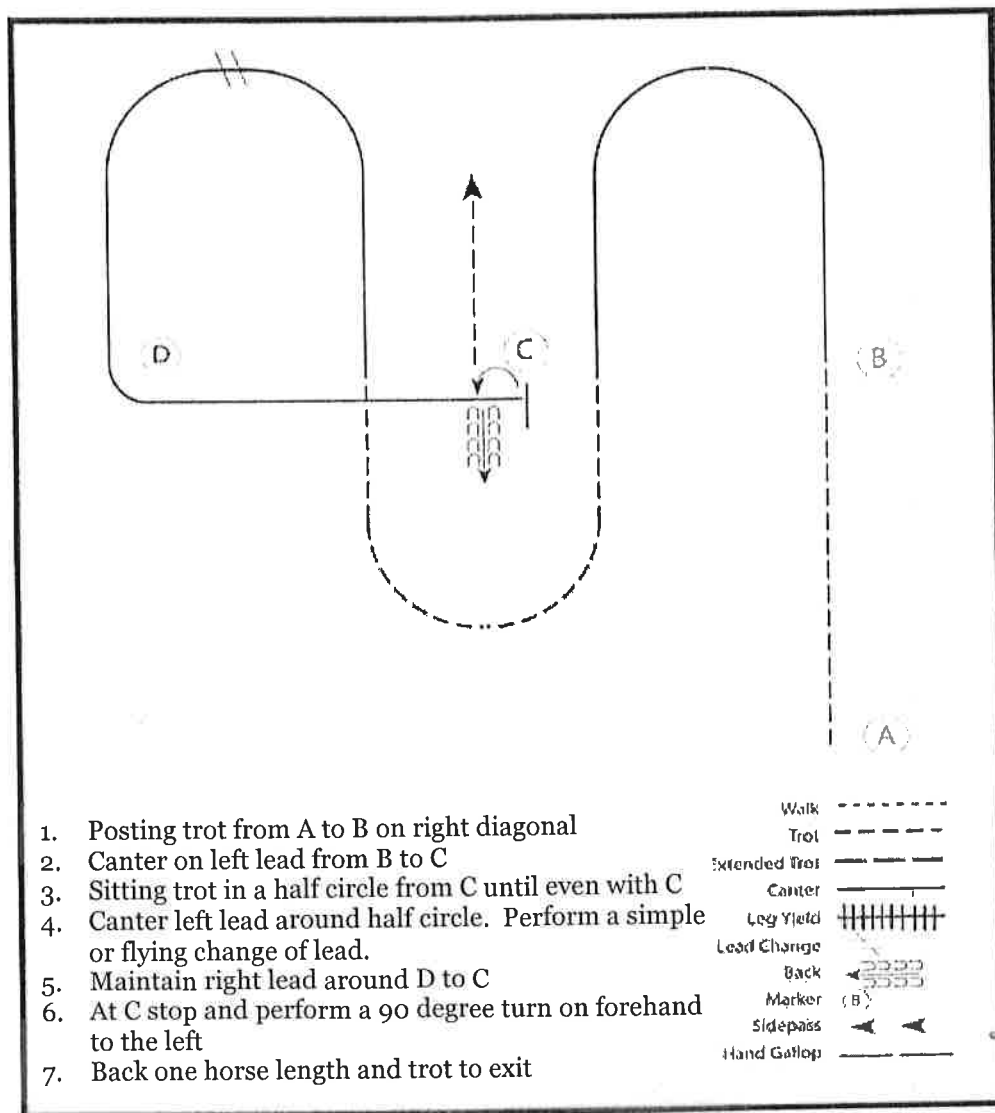

Western Horsemanship – Walk/Trot

Classes J-10, 129, 130

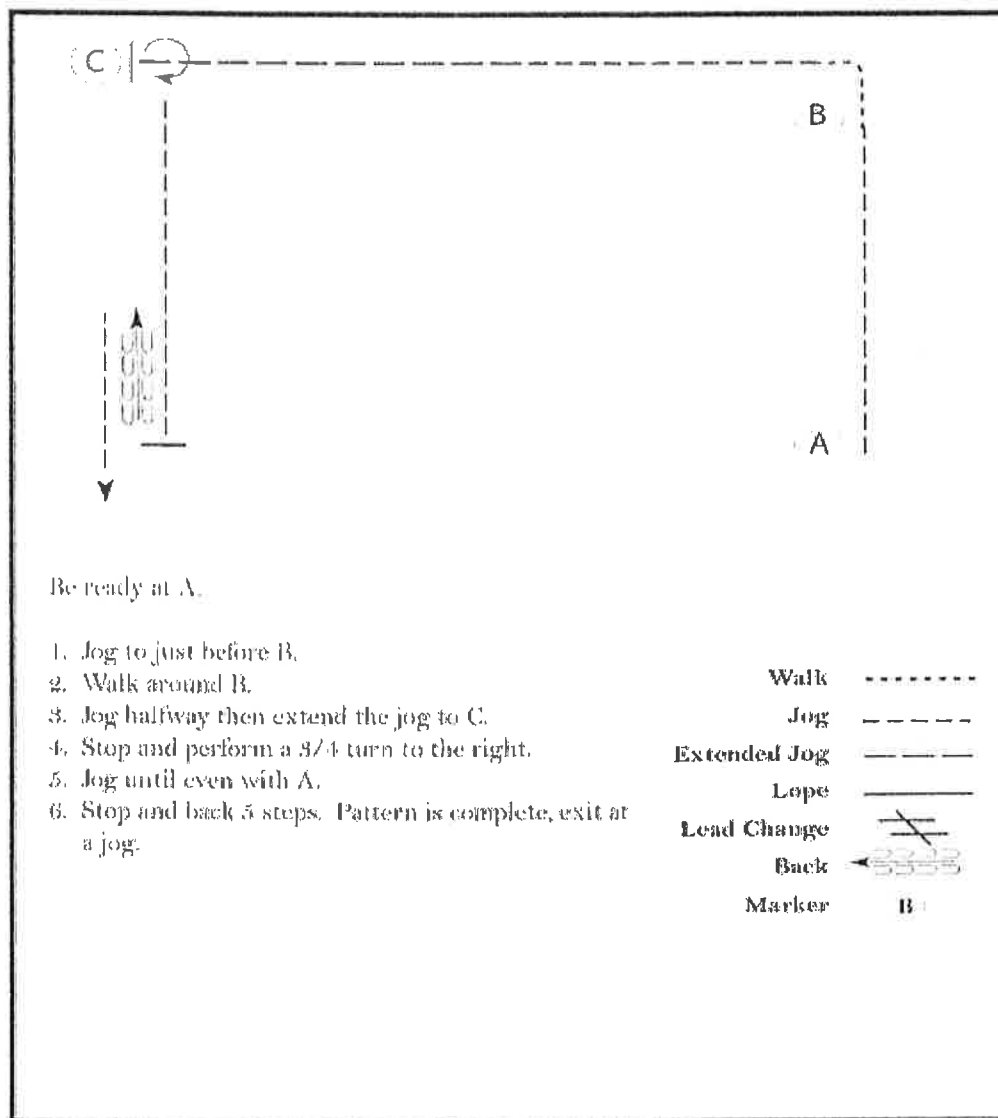

Western Horsemanship

Classes 132, 133, 134, 135, 136

Be ready before marker A.

1. Walk to A.
2. Stop and back approximately one horse length.
3. Execute a 3/4 turn to the right and lope on the right lead.
4. Perform a simple lead change and lope on the left lead to B.
5. Stop at B and execute a 1/2 turn to the right.
6. Jog to exit.

Follow the instructions of your ring steward.

Walk	-----
Jog	- - - - -
Extended Jog	- - - - -
Lope	—————
Leg Yield	
Lead Change	↔
Back	←←←←←
Marker	⊙
Sidepass	← →

Western Horsemanship

Classes J11, 131

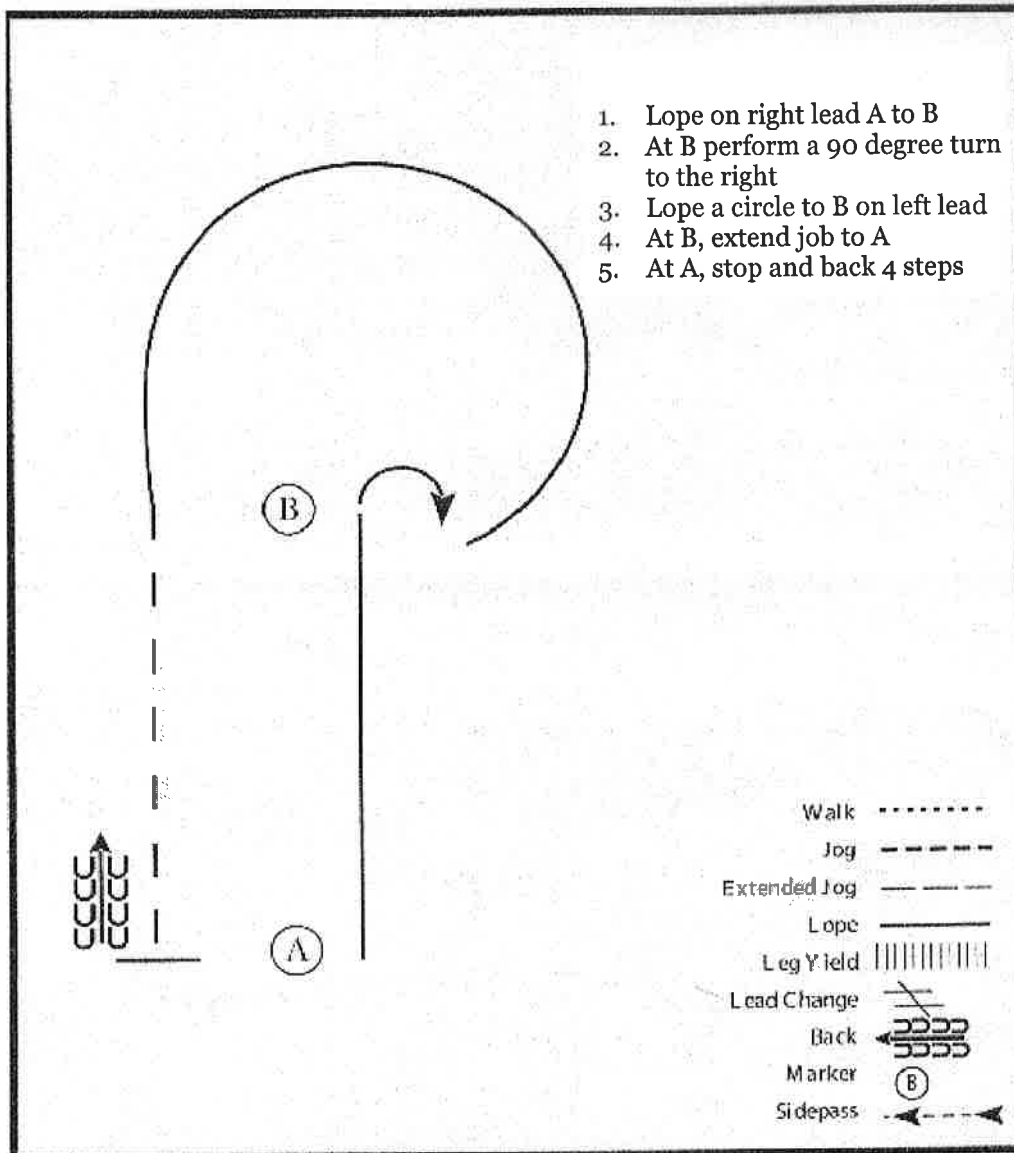

Bareback Western Horsemanship

Classes 143, 144

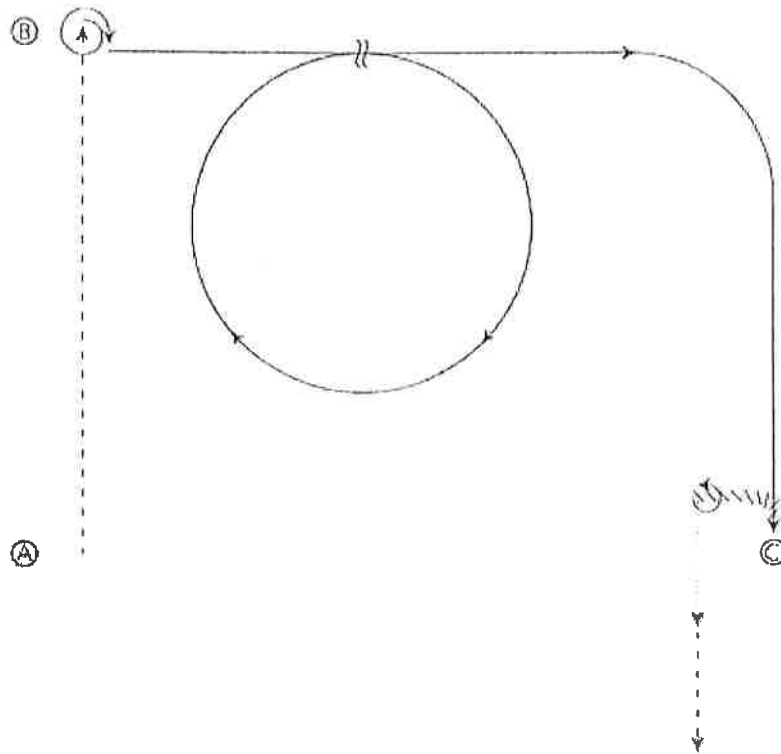

KEY

.....	WALK
- - - -	JOG
- . - . - .	EXTENDED JOG
————	LOPE
///////	BACK
~~~~~	CHANGE LEADS
~~~~~	SIDEPASS
⊙	MARKER

1. Begin at A and jog to B
2. At B stop, execute a 450 degree turn on the haunches to the right
3. Lope on the right lead in circle
4. Perform lead change (simple or flying) and lope on left lead to C
5. At C, stop and back an arc
6. Execute 270 degree turn on the forehand to the left
7. Walk forward several steps, proceed at a jog to exit

Miniature Hunter in Hand

Class 89

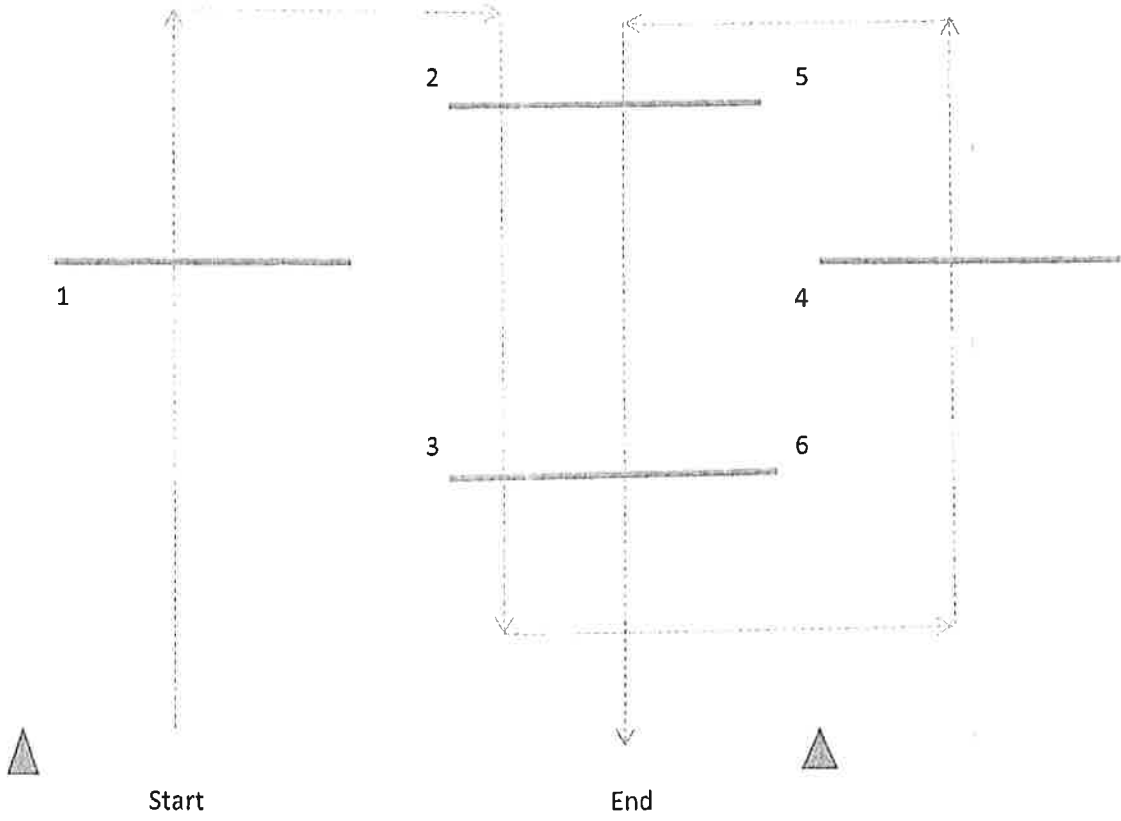

Pony Jumping in Hand
Miniature Jumping in Hand
AM & YA Pony/Miniature Jumping in Hand

Classes 90, 91, 92, 93

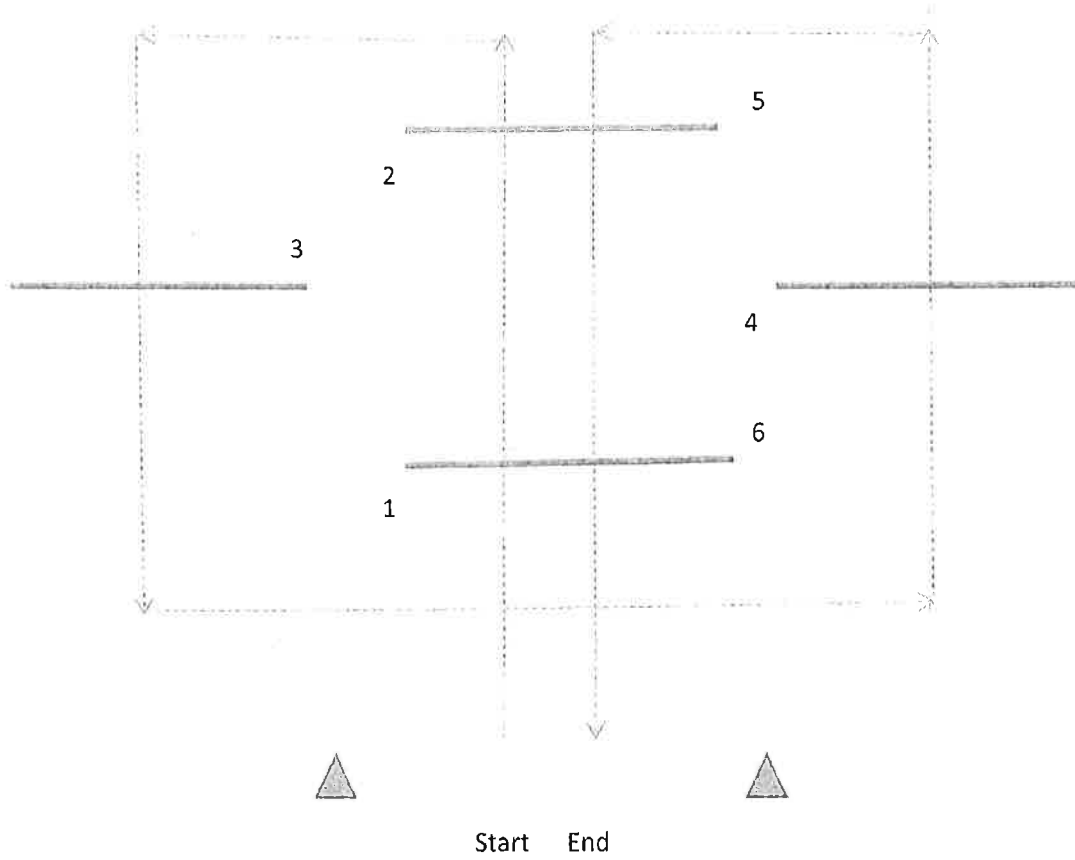

Trail Horse
Solid Registry Trail
AM Novice Trail
AM & YA Trail

Classes J-7, 98, 99, 100, 101, 102

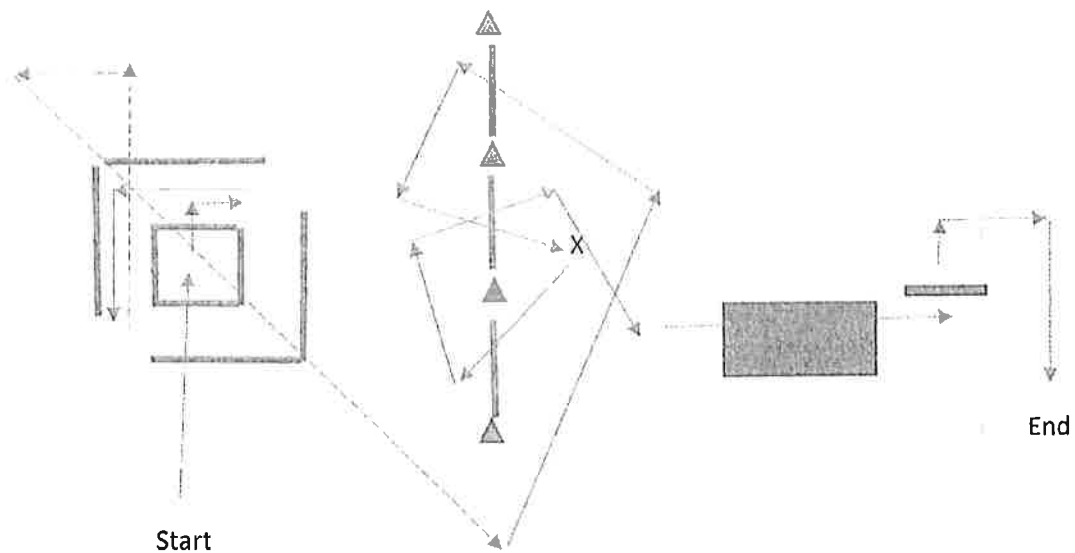

1. Walk into box perform 360 degree turn to right
2. Walk out and turn right in chute
3. Back L thru chute
4. Jog out of chute and thru box
5. Left lead lope around cones and over logs
6. Flying or simple lead change and right lead lope around cones and over logs
7. Walk over bridge
8. Perform left hand push gate
9. Exit at walk

Pony Trail In Hand
Miniature Trail in Hand
AM & YA Pony/Miniature Trail in Hand
YA Walk/Trot Trail 11 & Under
AM Walk/Trot Trail

Classes 94, 95, 96, 97, 103, 104

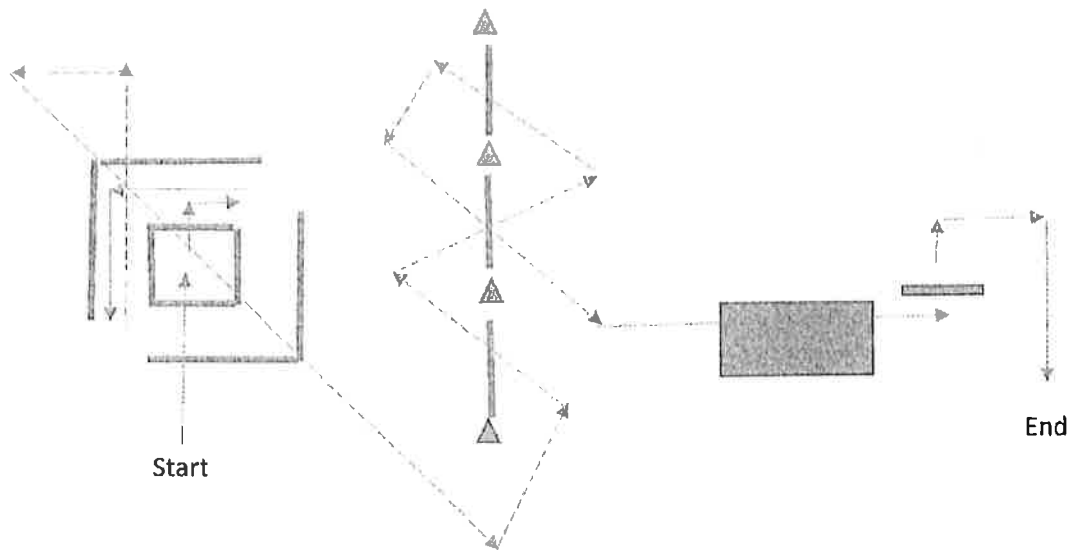

1. Walk into box, perform 360 degree turn to right
2. Walk out and turn right In chute
3. Back L thru chute
4. Jog out of chute, thru box, over logs and around cones
5. Walk over bridge
6. Perform left hand push gate
7. Exit at walk



WDA A 2017 WESTERN DRESSAGE BASIC LEVEL TEST 4
WESTERN DRESSAGE ASSOCIATION® OF AMERICA

PURPOSE
Tests confirm that the horse is supple and moves freely forward in a clear steady rhythm, accepting light contact with the bit. The horse demonstrates greater understanding of the aids and calm acceptance of the bridle; greater emphasis is placed on relaxation, harmony, rideability and pure gaits. The horse is beginning to develop more impulsion and balance.

NEW REQUIREMENTS
Serpentine on centerline at the working jog

Free walk on 20m half circle

ENTRY NO: _____
ARENA SIZE:
Small (40m x 20m) or Large (60m x 20m)
AVERAGE RIDE TIME:
4:15 (Small) or 5:00 (Large)

MAXIMUM PTS: 250

All jog work may be ridden sitting or rising.

*COEFFICIENT

		TEST	DIRECTIVES	POINTS	TOTAL	REMARKS
1	A	Enter working jog	Straightness; regularity and quality of the jog; willing, smooth transitions in and out square, straight halt; immobility; willingness.			
	X	Halt through the walk, salute Proceed working jog				
2	C	Track left, working jog	Balance and bend in the turn and corner; regularity and quality of the jog.			
3	E	Circle left 20m, free jog	Stretch forward and downward over topline with relaxation maintaining balance, tempo and regularity of jog; bend on the circle and in corner; smooth, willing release of the reins and transition to working jog.	2		
	Before E	Gather the reins, working jog				
4	A - C	Serpentine quarterline to quarterline 3 equal loops, working jog	Balance, correct bend and placement of loops; regularity and quality of the jog.	2		
5	Between C & H	Develop working lope, left lead	Willing, smooth transition; regularity and quality of the lope; balance and bend in the corner.			
6	E	Circle left 20m, working lope	Balance and bend on the circle and in the corners; regularity and quality of the lope.			
	K - A - F	Working lope				
7	F - X - H	Change rein, working lope	Straightness on diagonal; regularity and quality of the lope; willing, smooth transition; balance and bend in the corner; regularity and quality of the jog.			
	X	Working jog				
8	H - C - M	Working jog	Straightness on diagonal; balance and bend in the corners; regularity and quality of the jog; willing smooth transition; regularity and quality of the walk.			
	M	Working walk				
9	B - E	Half circle right 20m, free walk	Horse willing to freely stretch the neck forward and down; relaxation; swing through the back; ground cover; regularity and quality of the walks; willing, smooth transition.	2		
	E	Working walk				
10	H	Working jog	Willing, smooth transition; Balance and bend in the corner; regularity and quality of the jog.			
11	C - A	Serpentine quarterline to quarterline 3 loops, working jog	Balance, correct bend and placement of loops; regularity and quality of the jog.	2		
12	Between A & K	Develop working lope, right lead	Willing, smooth transition; regularity and quality of the lope; balance and bend in the corner.			
13	E	Circle right 20m, working lope	Balance and bend on the circle; regularity and quality of the lope.			
	H - C - M	Working lope				
14	M - X - K	Change rein, working lope	Straightness on diagonal; regularity and quality of the lope; willing, smooth transition; balance and bend in the corner; regularity and quality of the jog.			
	X	Working jog				
15	A	Down centerline	Balance and bend in the turn; straightness; regularity and quality of the jog and walk; willing, smooth transition; balance in downward transition to square, straight halt; immobility.			
	X	Halt through the working walk, salute				

Leave arena at A in a walk with looped or long reins.



WDAA 2017 WESTERN DRESSAGE BASIC LEVEL TEST 4
 WESTERN DRESSAGE ASSOCIATION® OF AMERICA

*COEFFICIENT

COLLECTIVE MARKS	POINTS	* COEFFICIENT	TOTAL	ERRORS (deduct)
GAITS: freedom and regularity.		1		
IMPULSION: desire to move forward with suppleness of the back and steady tempo		1		
RIDER'S POSITION, SEAT AND HANDS: well-balanced elastic seat demonstrating vertical, centered alignment, with light independent contact from hand(s)		1		
RIDER'S CORRECT AND EFFECTIVE USE OF THE AIDS: evidenced by the horse's responsiveness; steady elastic connection cultivating athletic expression. Accuracy - precise placement of the figures and transitions, the effectiveness of the rider's aids determines the accurate fulfillment of the required movements of the tests		1		
HARMONY: The horse accepts the aids and influence of the rider with attention, relaxation and confidence; and demonstrates a willing partnership between horse and rider resulting in a free flowing performance.		2		
SUBTOTAL:	total of points and coefficients above			
ERRORS:	subtract from subtotal			
TOTAL POINTS: (max points 250)	subtotal minus any errors			

REMARKS:

Attention competitors submitting points to WDAA for the Horse Lifetime Points & Awards Program: Only this bottom portion needs to be submitted along with the Test/Rail Submission Form to verify your points. Please go to www.westerndressageassociation.org for more information.

WDAA 2017 BASIC LEVEL TEST 4

_____ Name of Competition
_____ Date of Competition
_____ Name and Number of Horse
_____ Name of Rider
Final Score Maximum Points: 250
_____ Points / Percent
_____ Name of Judge
_____ Signature of Judge

AM & YA Reinsmanship Pony/Miniature Horse

Classes 108, 109

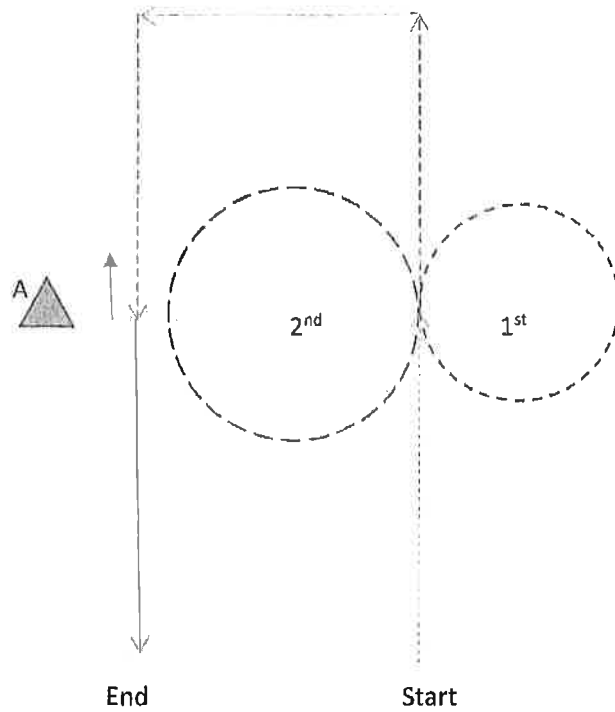

Start at medium trot
Circle right at A at medium trot
Extended trot and larger circle to left
Continue extended trot to A
Halt and reinback 5 steps
Exit at walk